



FOR APPROVAL

承认书

产品名称/Type	LED 驱动器	
产品型号/Model	ELP3X1LS	
产品编码/ Product code:	DW003C3500	
输入电压/Input voltage	<input type="checkbox"/> 100-120VAC <input type="checkbox"/> 220-240VAC <input checked="" type="checkbox"/> 100-240VAC <input type="checkbox"/> 其他 VAC	
输出模式/Out type	<input checked="" type="checkbox"/> 恒流/C.C <input type="checkbox"/> 恒压/C.V	
绝缘等级/Insulation	<input type="checkbox"/> Class I <input checked="" type="checkbox"/> Class II	
防护等级/IP Grade	<input checked="" type="checkbox"/> IP20 <input type="checkbox"/> IP65 <input type="checkbox"/> IP____	
安装方式/Installation	<input type="checkbox"/> 独立式/Independent <input checked="" type="checkbox"/> 内装式/build-in <input type="checkbox"/> 插墙式/Plug-in	
RoHS	符合欧盟 RoHS 要求 Conform to RoHS	
客户/CUSTOMER		
客户编号/ Customer part NO.		
客户认可回签(章) AUTHORIZED SIGNATURE &COMPANY CHOP		
编制/Drew up by:		日期 Date
批准/Approved by:	熊川高	日期 Date 2012.03.16

EAGLERISE ELECTRIC & ELECTRONIC (CHINA) CO., LTD.

Add: Gui cheng Sci-Tech Industrial Park, Jian ping Road, Nan hai District, Fo shan City, Guangdong Province, P.R. China

Tel: (0757) 86256767 Fax: (0757) 86256780

DZ-YF3-002-02D

一. KEY FEATURES (产品特点)

<p>▲Universal Input(100-240VAC) (输入电压 100-240V)</p> <p>▲Protections: short circuit/over load/over voltage/over temperature (保护功能: 短路/输出过载/输出过压/过温)</p> <p>▲IP20 Ingress protection (IP20 防护等级)</p> <p>▲Power Factor (功率因数) PF\geq0.5</p> <p>▲Efficiency (效率) \geq74%</p>	<p>Picture(产品图片)</p> 
--	---

二.ELECTRICAL SPECIFICATIONS (电气规格)

类别	Item 项目	Technical Norm 技术指标
Input (输入特性)	Rated input voltage(额定输入电压范围)	100-240VAC
	Range of input voltage (输入电压范围)	90-264VAC
	Frequency(Hz) (输入频率范围)	50/60 Hz
	Power Factor (功率因素)	PF \geq 0.5@Full Load,230VAC
	Current (输入电流)	0.1A MAX.
	Inrush Current (涌入电流)	15A MAX.(230VAC)
	Unload Power Consumption(空载功耗)	<0.3W
Output (输出特性)	Unload voltage (空载电压)	14VDC MAX.
	Constant current (恒流)	350mA
	Current Accuracy (电流精度)	\pm 8%
	start-up time (启动时间)	<1S
	Load Voltage rang (负载电压范围)	3-10.5V
	Recommend maximum numbers of LED in series (建议串联最大灯数量)	3PCS(Vf \leq 3.5V)
	Load power range(负载功率范围)	1-3.6W
	Voltage Regulation (电压调整率)	\leq 5%
	Load Regulation (负载调整率)	\leq 5%
	Efficiency (效率)	\geq 74%
	Current Ripple (电流纹波)	<70mAp-p
Dimming (调光)	Dimmable or not (调光)	NA
	Dimming mode(调光模式)	NA
Protection (保护特性)	Over load protection	Protection type: Auto Restore(保护类型: 自动恢复)
	Short circuit Protection(短路)	Protection type: Auto Restore(保护类型: 自动恢复)
	Over Temperature protection (过温)	Protection type: Auto Restore(保护类型: 自动恢复)
Hi-pot (耐压)	Input-Output(V.AC)(输入-输出)	3750V/5mA/1min
	Leakage Current(泄漏电流)	<0.5mA
Isolation resistance (绝缘阻抗)	Input-Output: >4M Ω	
Environment/ Life span (环境特性/寿命)	Operating Temperature(工作温度)	-5 $^{\circ}$ C...+45 $^{\circ}$ C (Refer to output load derating curve)
	Storage Temperature(存储温度)	-10 $^{\circ}$ C...+60 $^{\circ}$ C
	Humidity(湿度)	10%-95%RH

	Life time	>30,000h @25°C
feature (特征)	Dimension (尺寸)(LXWXH)	40.8*37.8*21.5(LXWXH)mm
	Weight(重量)	/
Safety & EMC (安规与电磁兼容)	Approval (认证)	CE
	Safety standards (安全标准)	EN 61347-1; EN61347-2-13 EN60598-1; EN60598-2-6
	EMC standards (电磁兼容性标准)	EN55015; EN61547 EN61000-3-2 ; EN61000-3-3
Note (备注)	<p>1:All parameters , if not specified, are measured at 230VAC rated input and 25°C ambient temperature (所有的参数无特别说明的都是在额定的输入交流 230V 和 25°C 的环境温度下测得.)</p> <p>2. The Accuracy is the total Accuracy which Comprises the Line Regulation ,Load Regulation and Error (此精度包含了电压调整率、负载调整率以及设计误差)</p>	

三. MECHANICAL SPECIFICATIONS (机械规格)

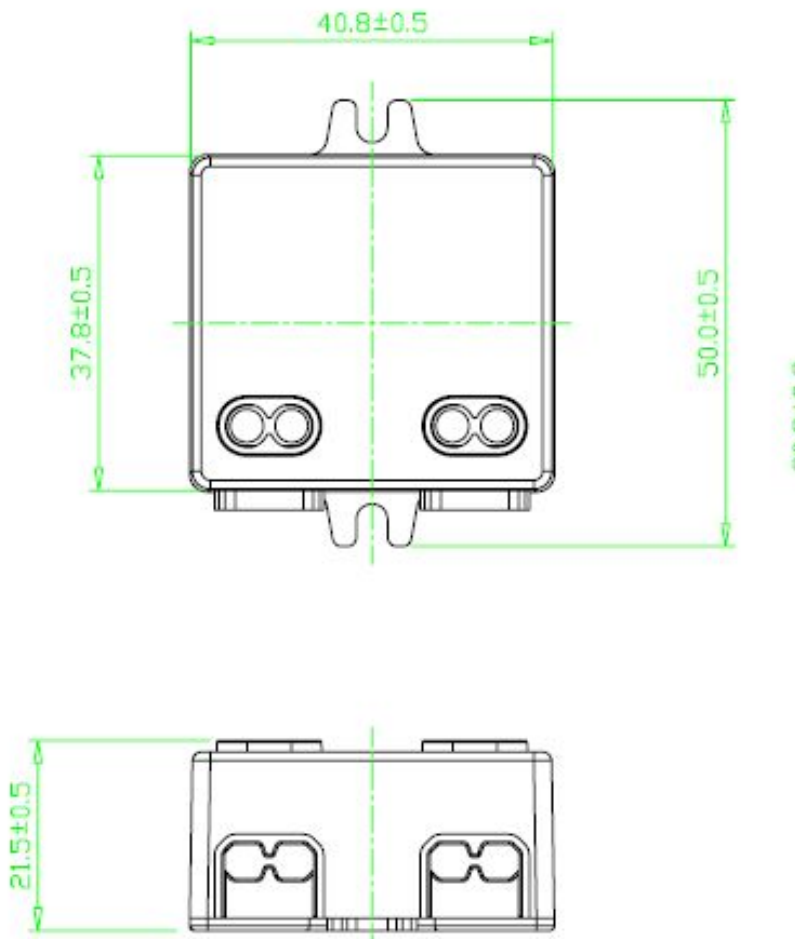

四、DESCRIPTIONS OF CHANGE (变更描述)

变更项目 ITEM	变更前 BEFORE	变更后 AFTER	版本 Version	变更日期 DATE